

STR-G3

SERVICE MANUAL

US Model
Canadian Model
PX Model



Refer to the previously issued STR-G1ES Service Manual (9-959-241-11) for the remote commander (RM-VP1).

Manufactured under license from Dolby Laboratories Licensing Corporation.
"DOLBY" and the double-D symbol  are trademarks of Dolby Laboratories Licensing Corporation.

SPECIFICATIONS

Audio Power Specifications

POWER OUTPUT AND TOTAL HARMONIC DISTORTION:

With 8 ohm loads both channels driven, from 20 - 20,000 Hz; rated 110 watts per channel minimum RMS power, with no more than 0.3 % total harmonic distortion from 250 milliwatts to rated output.

	Surround mode (at 1 kHz, THD 0.8% 8 ohms)
FRONT	100 W + 100 W
CENTER ^{a)}	100 W
REAR	50 W + 50 W

^{a)} Only in the DOLBY SUR and THEATER modes.

Other Specifications

Dynamic power output (in the stereo mode)	8 ohms; at 1 kHz IHF	160 W + 160 W
	4 ohms; at 1 kHz IHF	225 W + 225 W
Frequency response	PHONO	RIAA equalization curve ± 0.5 dB
	CD, DAT/MD, TAPE, VIDEO 1,2,3, LD, SATL	10 Hz - 50 kHz ± 1 dB
Damping factor (8 ohms, at 1kHz)		50
Input sensitivity/impedance	PHONO MM	2.5 mV, 50 kilohms
	CD	300 mV, 50 kilohms
	DAT/MD TAPE, VIDEO 1,2,3, LD, SATL	250 mV 50 kilohms
S/N	PHONO MM	75 dB 75 dB ^{b)} (A, 2.5 mV)
	DAT/MD TAPE, VIDEO 1,2,3, LD, SATL	82 dB 82 dB ^{b)} (A, 150 mV)

^{b)} 78 IHF

— Continued on page 2 —

FM STEREO/FM-AM RECEIVER
SONY®

**SECTION 4
DIAGRAMS**

4-1. BLOCK DIAGRAM (OSD SECTION)

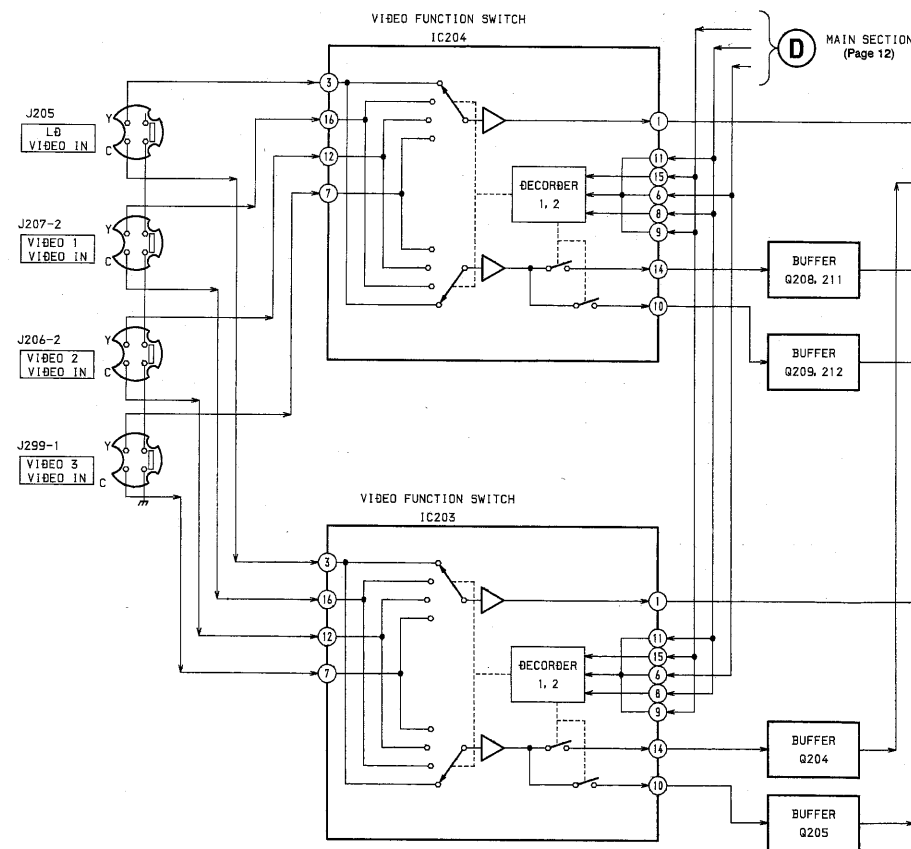
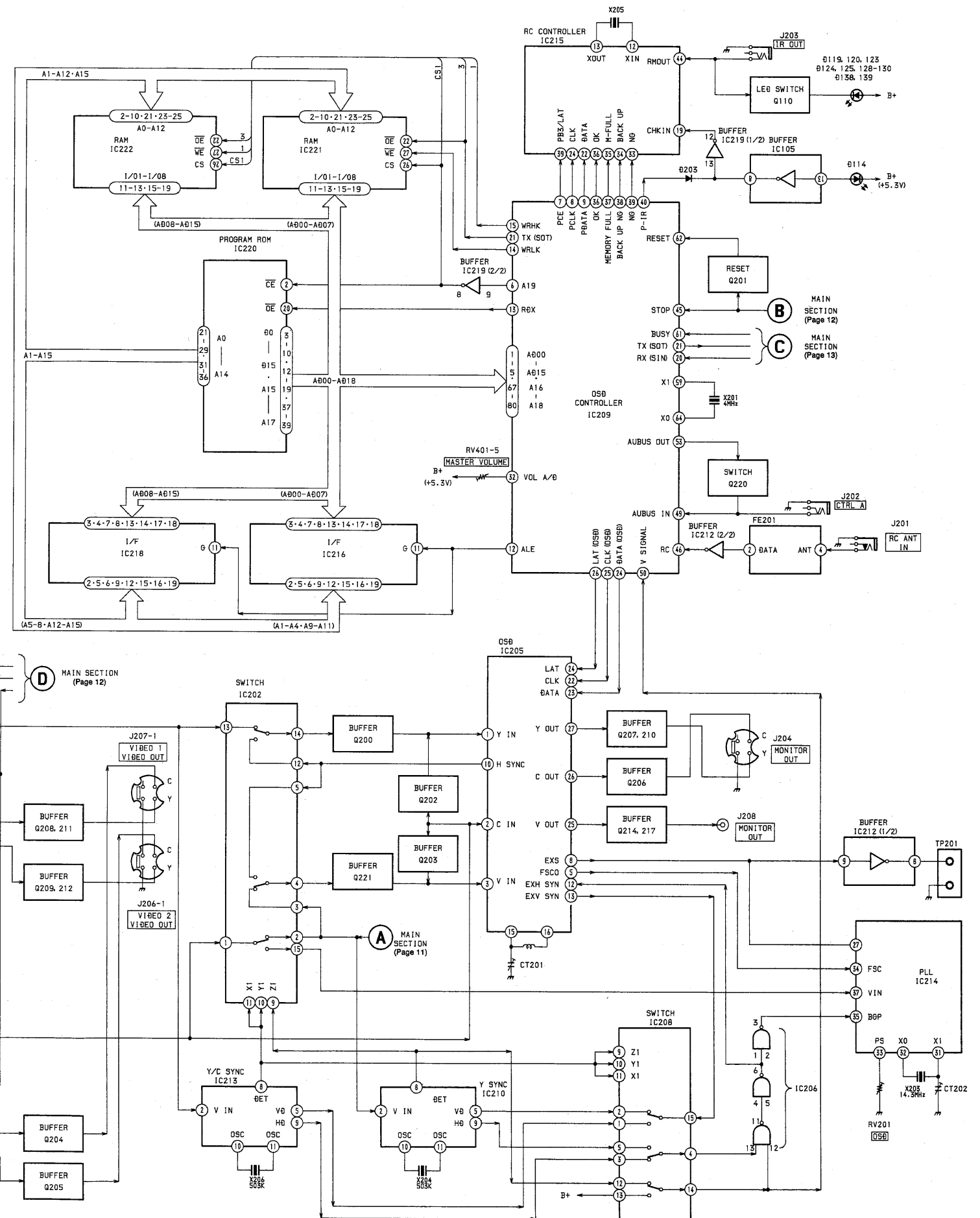

4-2. BLOCK DIAGRAM (MAIN SECTION)

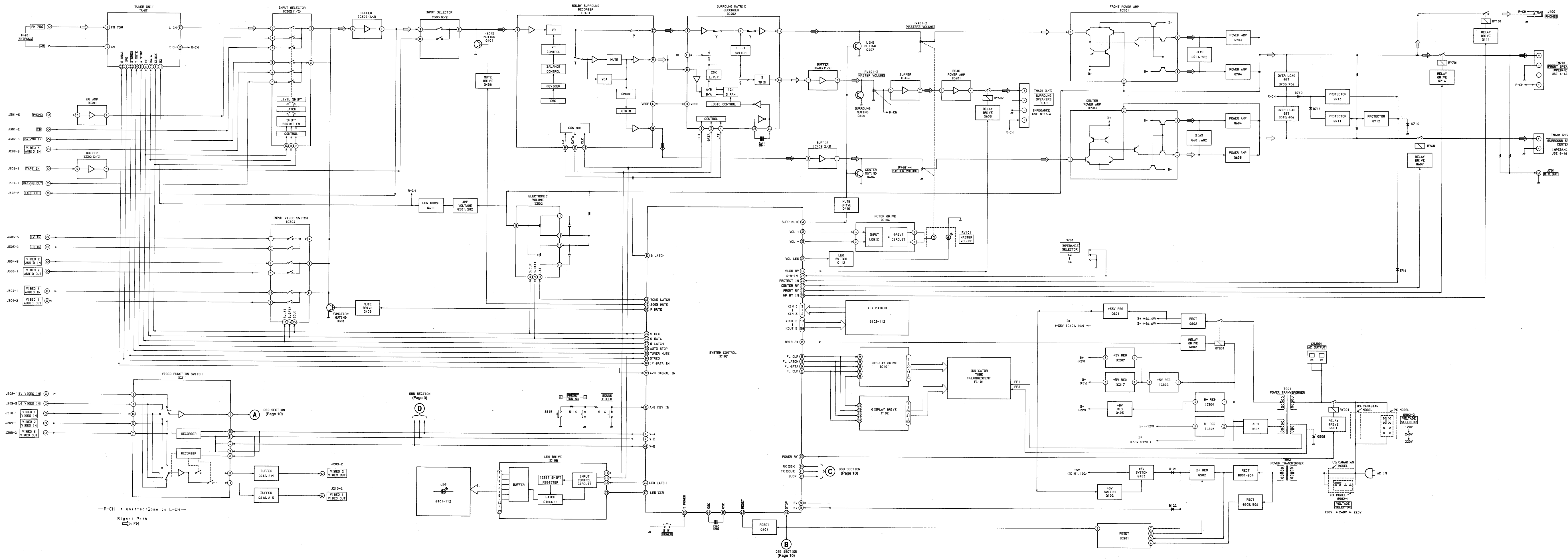

4-5. SCHEMATIC DIAGRAM (SURROUND SECTION)

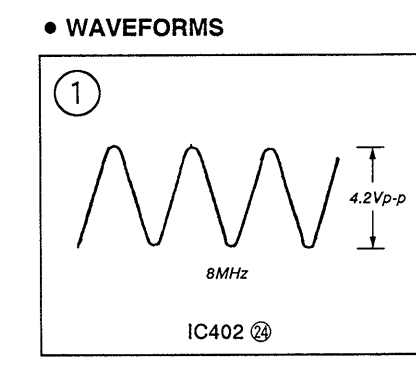
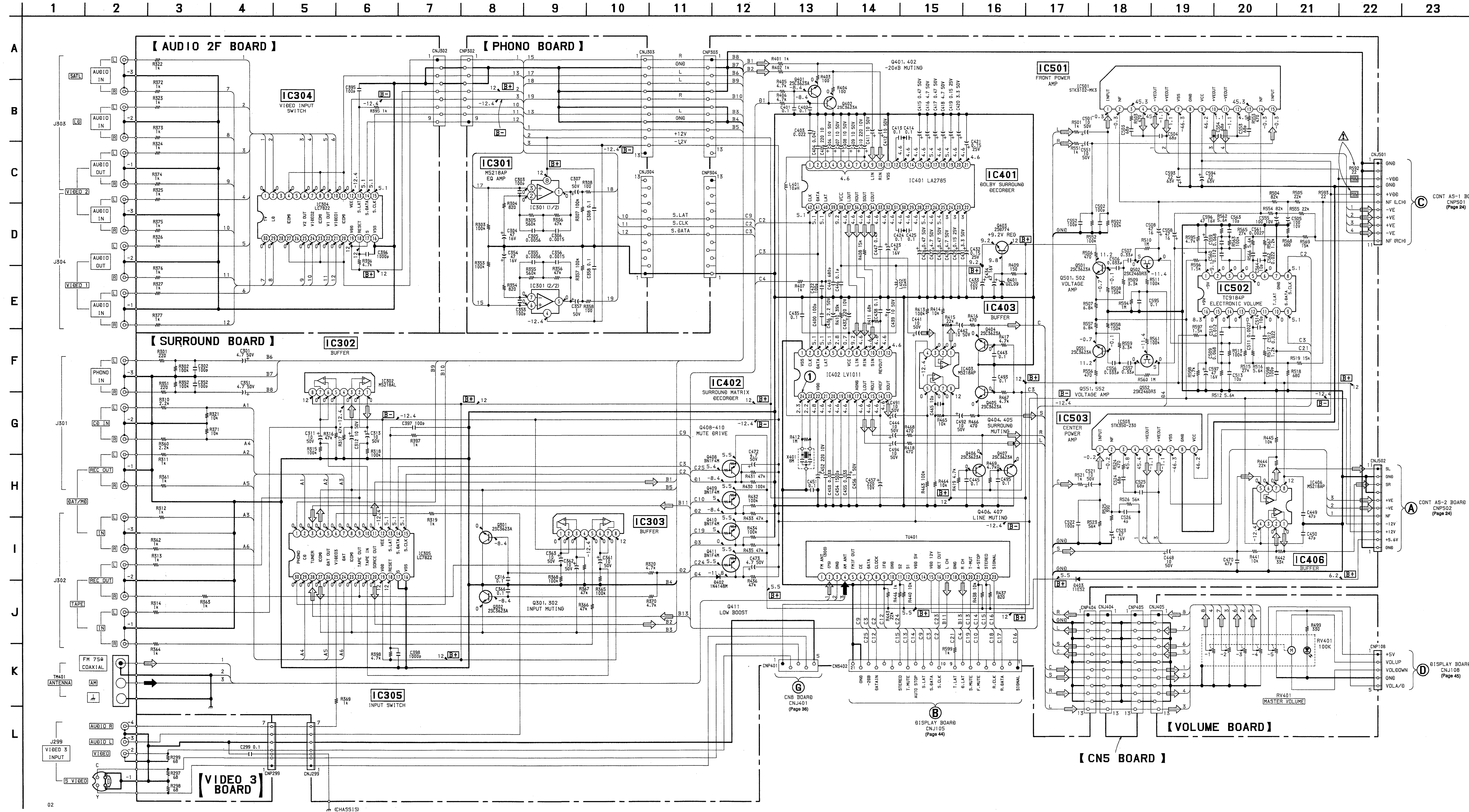

• IC BLOCK DIAGRAMS - SURROUND SECTION -

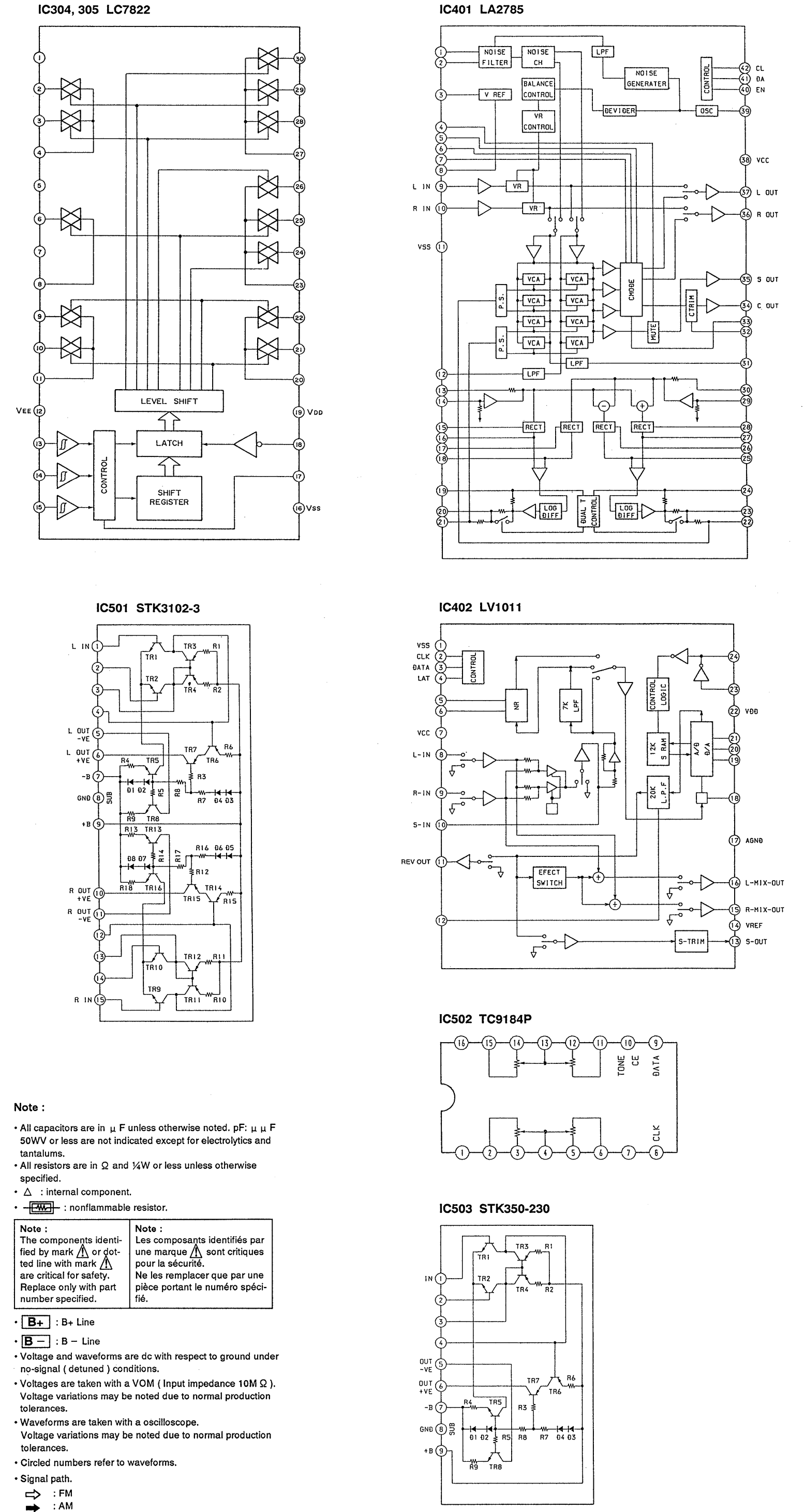

• IC BLOCK DIAGRAM - AMP SECTION -

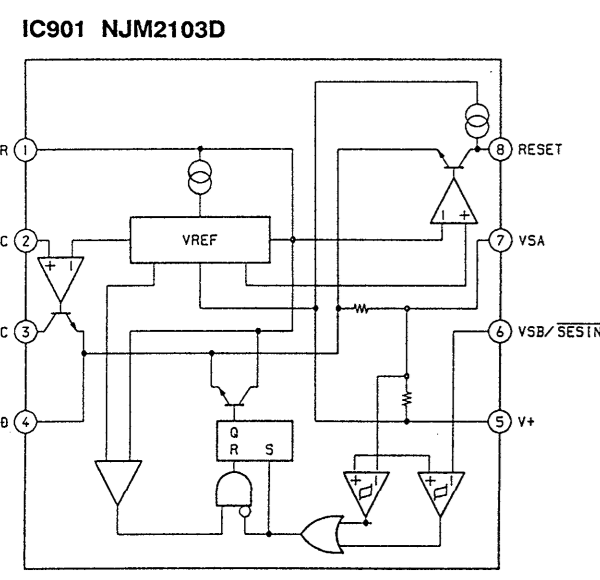

4-6. SCHEMATIC DIAGRAM (AMP SECTION)

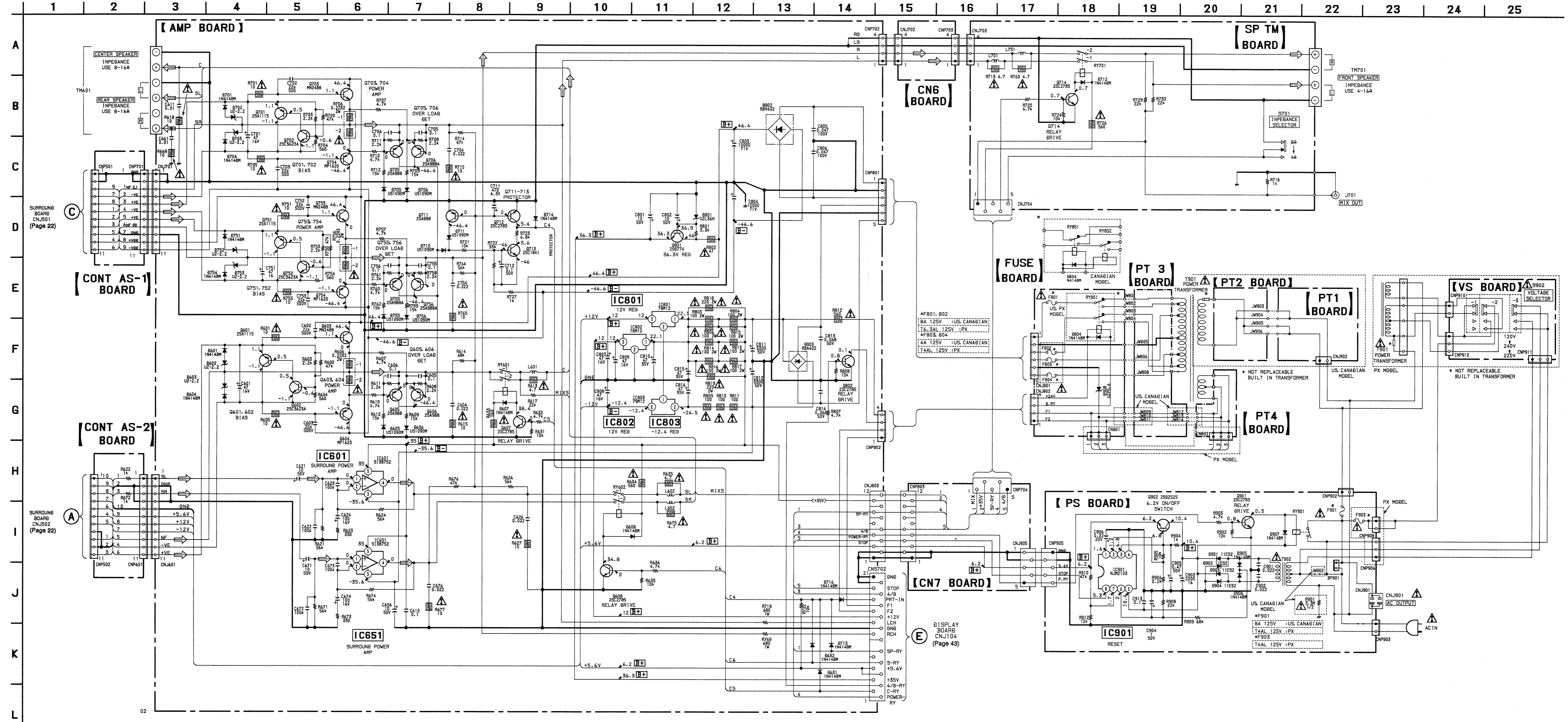

Note :

- All capacitors are in μ F unless otherwise noted. pF, μ F, μ F 50WV or less are not indicated except for electrolytics and tantalums.
- All resistors are in Ω and $\frac{1}{2}W$ or less unless otherwise specified.
- \square : nonflammable resistor.

Note :

The components identified by mark Δ or dotted line with mark Δ are critical for safety. Replace only with part number specified.

Les composants identifiés par une marque Δ ou une ligne pointillée avec une marque Δ sont critiques pour la sécurité. Ne les remplacer que par une pièce portant le numéro spécifié.

- \square : B+ Line
- \square : B- Line
- Voltages are taken with a VOM (Input impedance 10M Ω). Voltage variations may be noted due to normal production tolerances.
- Signal path.
- \rightarrow : FM

WAVEFORMS

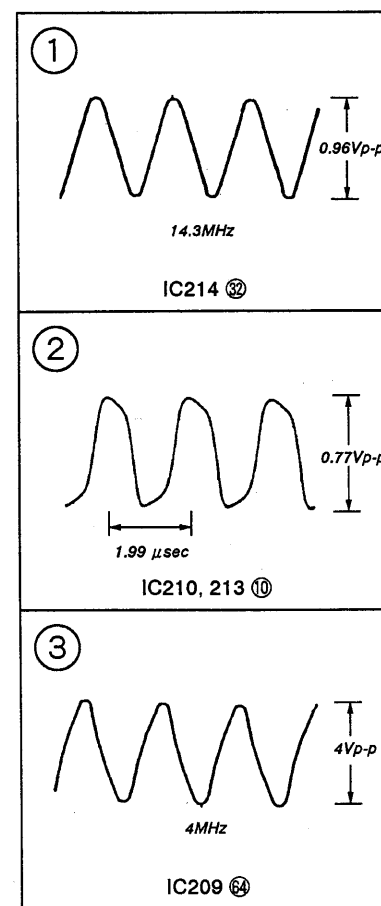

Note:

- All capacitors are in μ F unless otherwise noted. pF: μ F μ F 50WV or less are not indicated except for electrolytics and tantalums.
- All resistors are in Ω and $\frac{1}{2}W$ or less unless otherwise specified.
- Δ : internal component.
- \square : nonflammable resistor.

Note: The components identified by mark Δ or dotted line with mark Δ are critical for safety. Replace only with part number specified.

Note: Les composants identifiés par une marque Δ sont critiques pour la sécurité. Ne les remplacer que par une pièce portant le numéro spécifié.

- $B+$: B+ Line
- $B-$: B- Line
- \square : adjustment for repair.
- Voltage and waveforms are dc with respect to ground under no-signal conditions.
- Voltages are taken with a VOM (Input impedance 10M Ω). Voltage variations may be noted due to normal production tolerances.
- Waveforms are taken with an oscilloscope. Voltage variations may be noted due to normal production tolerances.
- Circled numbers refer to waveforms.

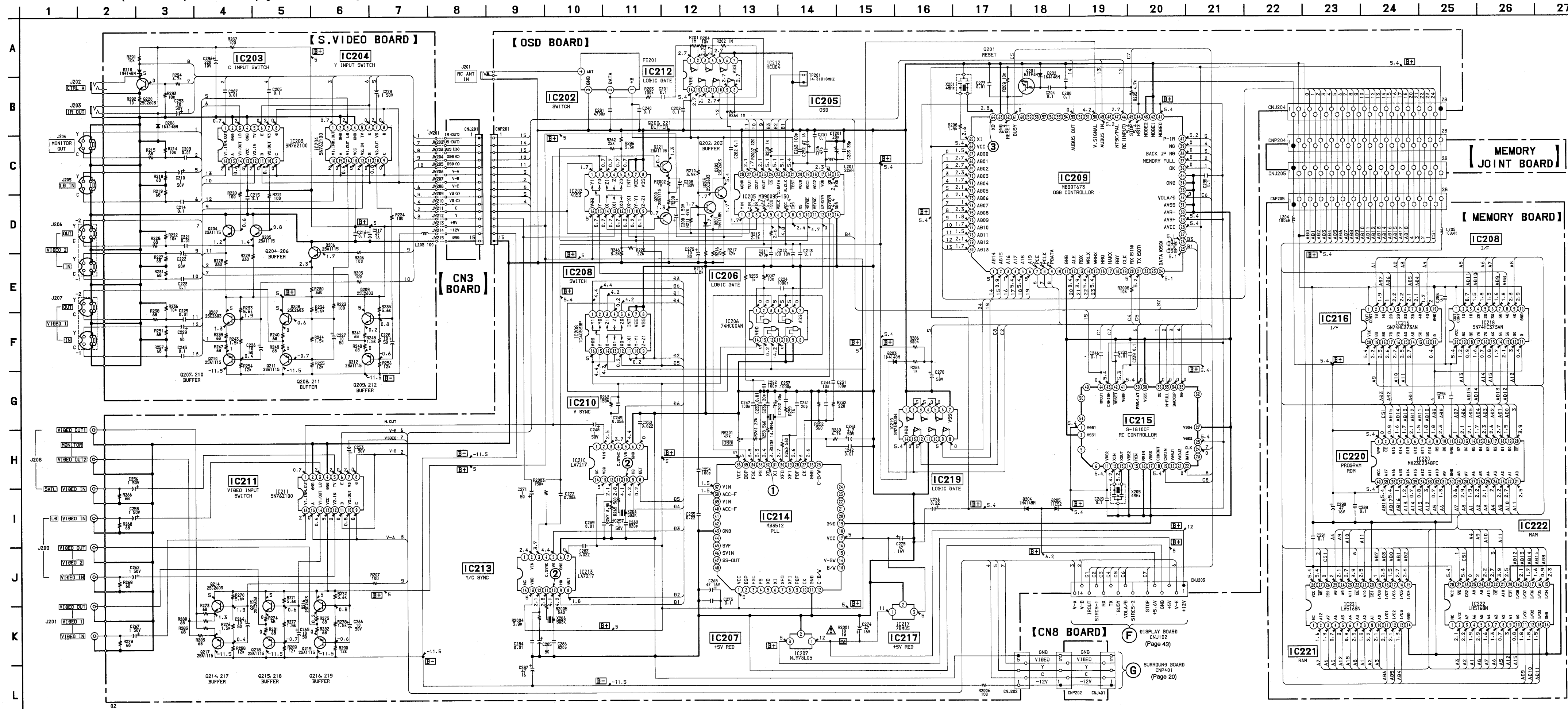

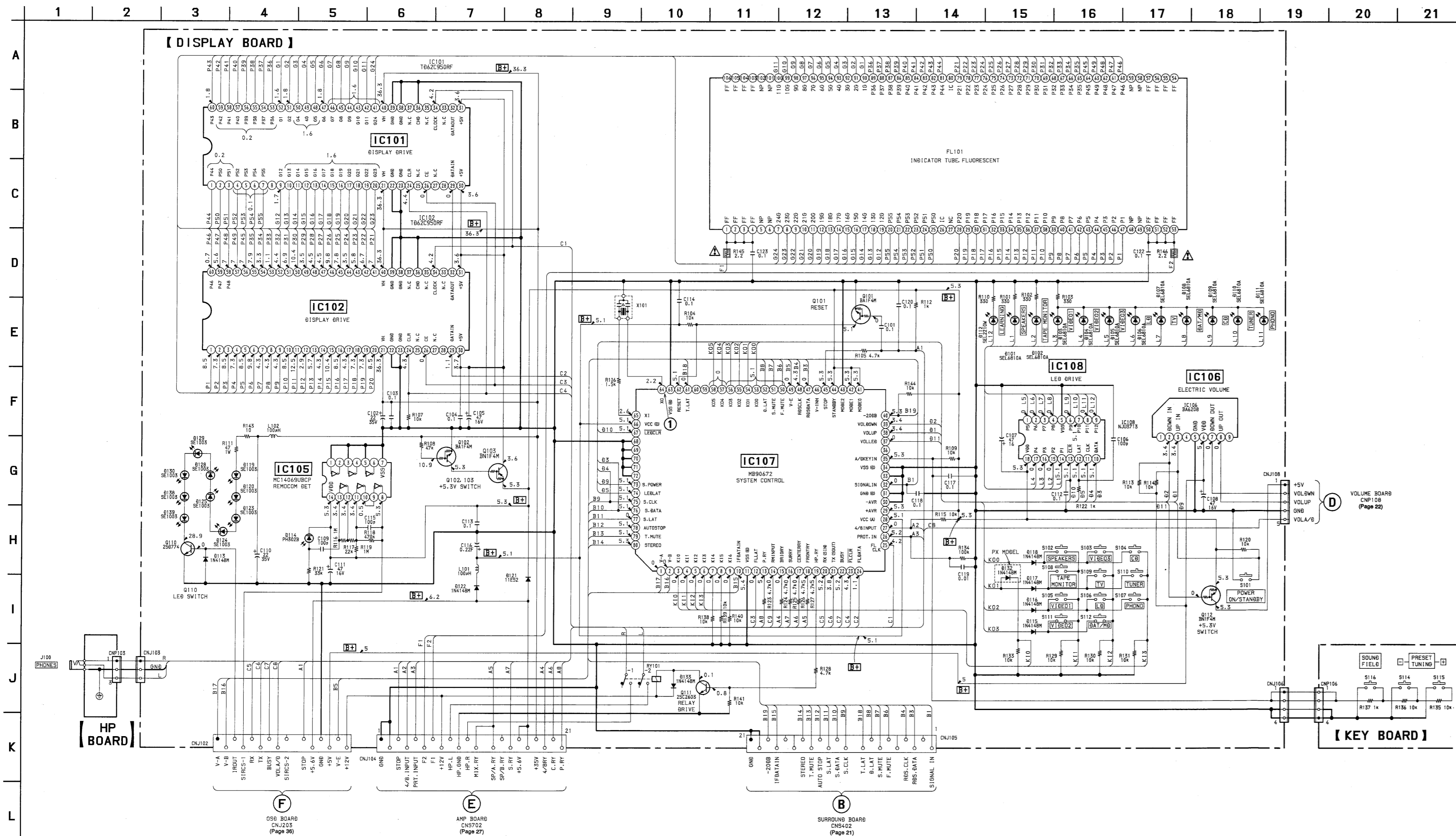

IC BLOCK DIAGRAMS - DISPLAY SECTION -

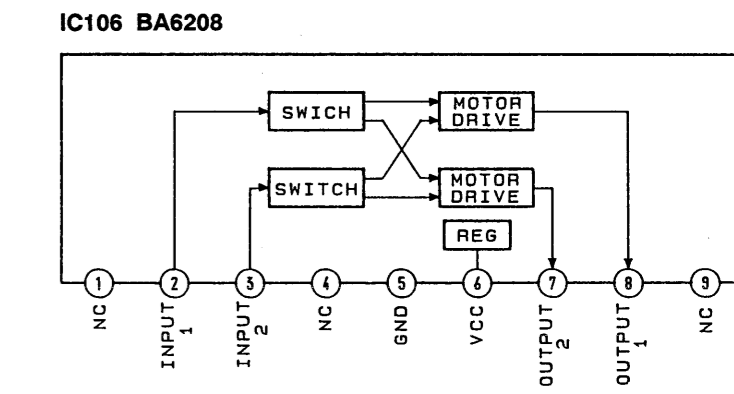
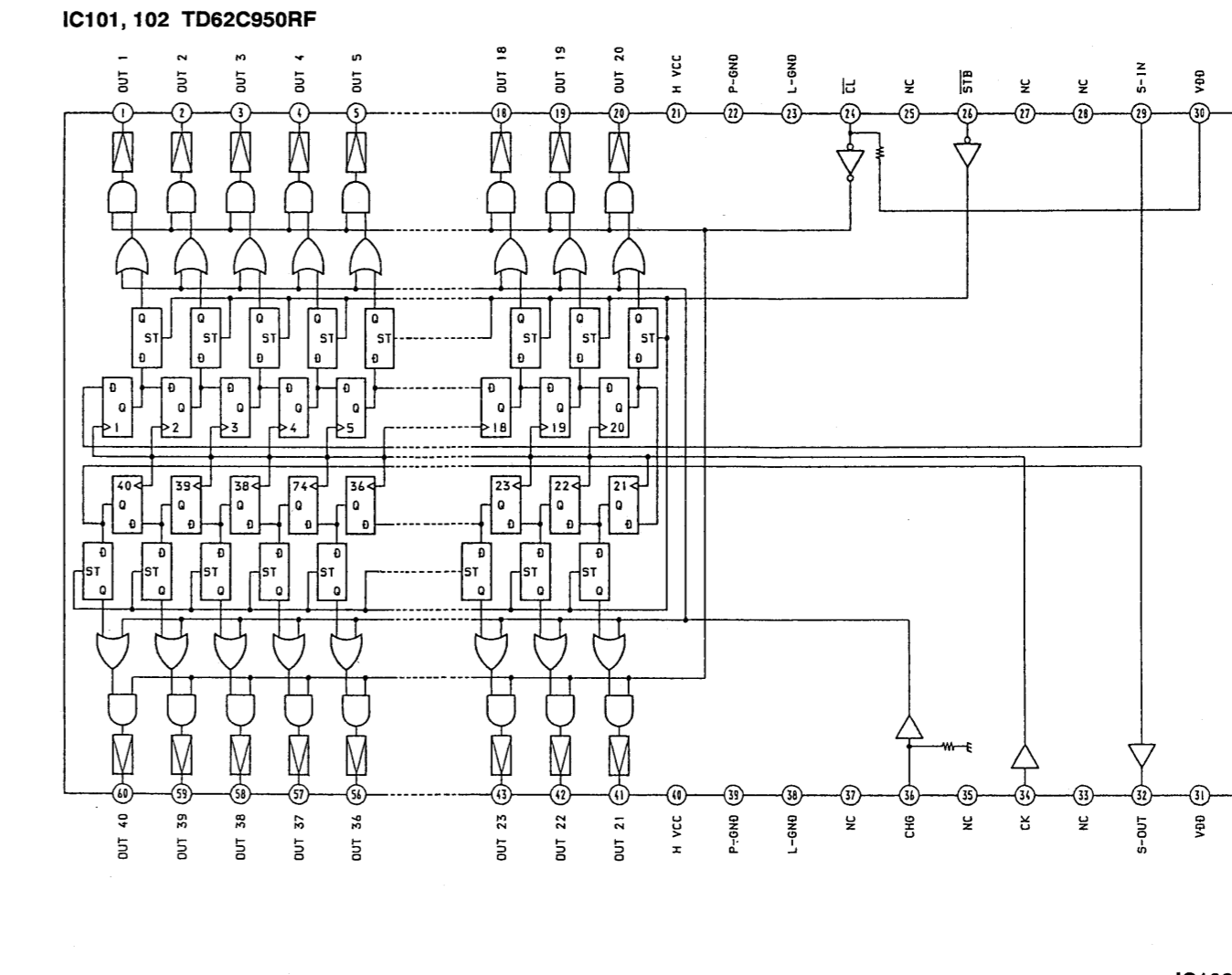

Note :

- All capacitors are in μF unless otherwise noted. pF: $\mu \mu F$ 50WV or less are not indicated except for electrolytics and tantalums.
- All resistors are in Ω and $\frac{1}{4}W$ or less unless otherwise specified.
- Δ : internal component.
- \square : nonflammable resistor.

Note : The components identified by mark Δ or dotted line with mark Δ are critical for safety. Replace only with part number specified.

Note : Les composants identifiés par une marque Δ sont critiques pour la sécurité. Ne les remplacer que par une pièce portant le numéro spécifié.

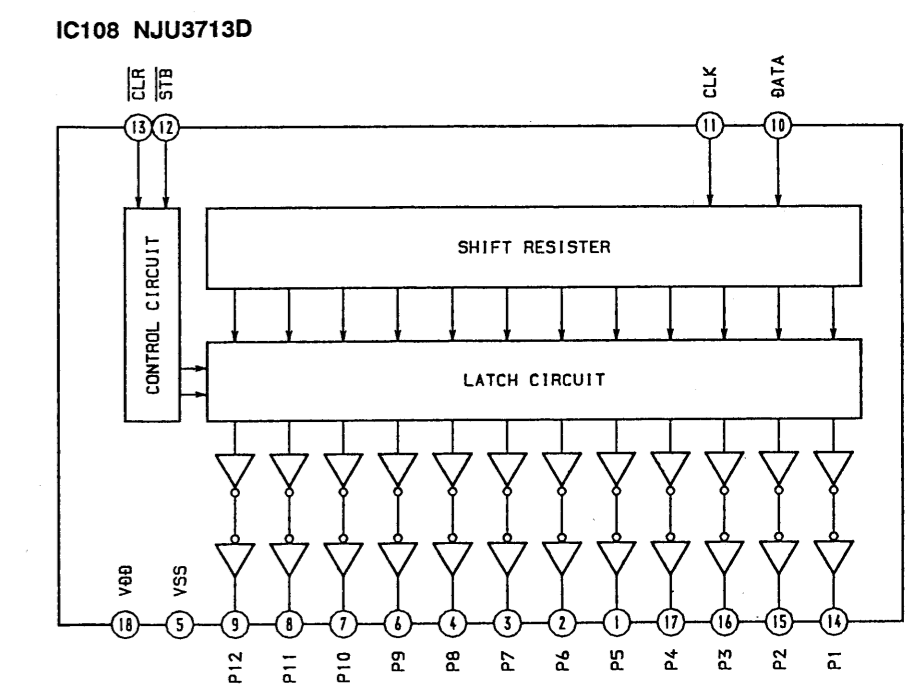
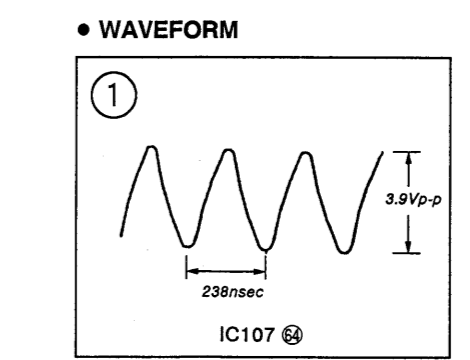

B+ : B+ Line

- Voltage and waveforms are dc with respect to ground under no-signal (detuned) conditions.
- Voltages are taken with a VOM (Input impedance 10M Ω). Voltage variations may be noted due to normal production tolerances.
- Waveforms are taken with an oscilloscope. Voltage variations may be noted due to normal production tolerances.
- Circled numbers refer to waveforms.